

Alfa Radio Ltd.

11211 - 154 St. Edmonton, Alberta, Canada T5M 1X8
sales@alfaradio.ca 780-466-5779 www.alfaradio.ca



Alfa Mini-RAS RAS BIG-RAS Rotators



Revised 12 APR 2022

<http://www.alfaradio.ca>

This manual is for use with units sold by Alfa Radio Ltd. of Edmonton, Alberta, Canada. on or after March 1, 2022. Units sold by others may have different firmware and may operate using different voltages.

Alfa Radio Ltd.

11211 - 154 St. Edmonton, Alberta, Canada T5M 1X8
sales@alfaradio.ca 780-466-5779 www.alfaradio.ca



Table of Contents

1 INTRODUCTION.....	3
2 SPECIFICATIONS.....	4
3 INSTALLATION ALFA MINI-RAS, RAS, BIG-RAS ROTATORS.....	5
3.1 WIRING.....	5
3.2 USING THE ALFA ROTATOR ON LONG CABLE RUNS.....	8
3.3 ROTATOR MOUNTING BOLTS.....	9
4 ROTATOR TESTING:.....	10
5 ROTATOR TROUBLESHOOTING.....	12
6 REPLACING REED SWITCH SENSOR.....	15
12 MONTH LIMITED WARRANTY.....	17

Alfa Radio Ltd.

11211 - 154 St. Edmonton, Alberta, Canada T5M 1X8
sales@alfaradio.ca 780-466-5779 www.alfaradio.ca



1 Introduction

Alfa Radio sells three azimuth-elevation rotators. The Mini-RAS for light Duty applications, the RAS for Medium Duty applications and the BIG-RAS for application that require a heavy duty rotator

These rotators use a double worm gear drive for reliable service which eliminates the requirement for a separate braking mechanism. The main Worm gear, the main bearing and the outside case of each Rotator is made of steel, making it very rugged and giving it a long life expectancy. The Rotators surface is covered with a powder coated paint, protecting against corrosion and each rotator will work with controllers Rot2Prog and/or MD-01/02.

Alfa Radio Ltd.

11211 - 154 St. Edmonton, Alberta, Canada T5M 1X8
sales@alfaradio.ca 780-466-5779 www.alfaradio.ca



2 Specifications

Rotator	Mini-RAS	RAS	BIG-RAS
Rotating Torque Rot2Prog @ 18V MD-01/02 @ 24V	1650 in lb or 186 N m 1970 in lb or 222 N m	1,800 in lb or 203 N m 3,240 in lb or 366 N m	8,000 in lb or 904 N m Contact Alfa Radio
Braking Torque in lbs/N m	8,000 in lb or 904 N m	14,000 in lb or 1582 N m	24,000 in lb or 2712 N m
Vertical Load	400lb or 181 Kg	550 lb or 250 Kg	>700 lb or 318 Kg
Brake Type	Double Worm	Double Worm	Double Worm
Encoder Type	Magnetic Reed Switch	Magnetic Reed Switch	Magnetic Reed Switch
Resolution	1 Pulse/Degree	1 Pulse/Degree	1 Pulse/0.5 Degree
Rotation Angle AZ Rotation Angle EL	360 +/- 180 (720) Deg 180 Deg	360 +/- 180 (720) Deg 180 Deg	360 +/- 180 (720) Deg 180 Deg
Rotation Time 360 Degrees Rot2Prog @ 18V MD-01/02 @ 24V	60 Seconds 46 Seconds	90 Seconds 45 Seconds	240 Seconds 145 Seconds
Electric Motor	12 V	12 V	12 V
Environment	-20 +50 Degree C	-20 +50 Degree C	-20 +50 Degree C
Mass of Rotator	23 lb or 10.3 Kg	42 lb or 19 kg	55 lb or 25 kg



3 INSTALLATION Alfa MINI-RAS, RAS, BIG-RAS Rotator

3.1 Wiring

The rotator unit must be wired to the control unit with an 8-wire cable; 4 wires - elevation (1,2,3,4) and 4 wires - azimuth (5,6,7,8). The gauge of the wires in the cable to connect the control unit to the rotator depends upon the distance between the rotator and the controller. The wire for the impulse sensing may be quite thin - #22 or similar, even for relatively long distances. Motor wire should be as follows:

! TIP:
Before final installation of equipment, it is strongly suggested you check out all functions and connections on a workbench.

<u>Length (distance)</u>	<u>Gauge</u>
10 m (32')	#18 (1.19 mm)
30 m (100')	#16 (1.42 mm)
60 m (200')	#14 (1.75 mm)

! CAUTION:
Do not accidentally switch the motor wires with the impulse wires. Damage to the control unit may occur!

Alfa Radio Ltd.

11211 - 154 St. Edmonton, Alberta, Canada T5M 1X8
sales@alfaradio.ca 780-466-5779 www.alfaradio.ca

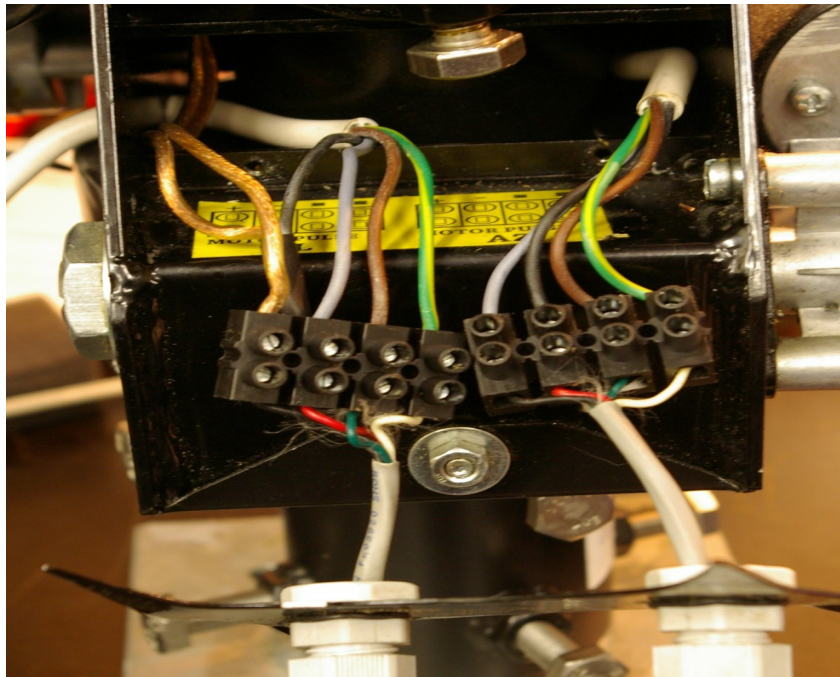

On the RAS and BIG-RAS Rotator, remove cover from the rotator and pull out the two 4 pin terminal strips. The Elevation terminal strip is on the left of the above picture and the Azimuth is on the right. Each terminal strip has pin 1 on the left and pin 4 on the right.

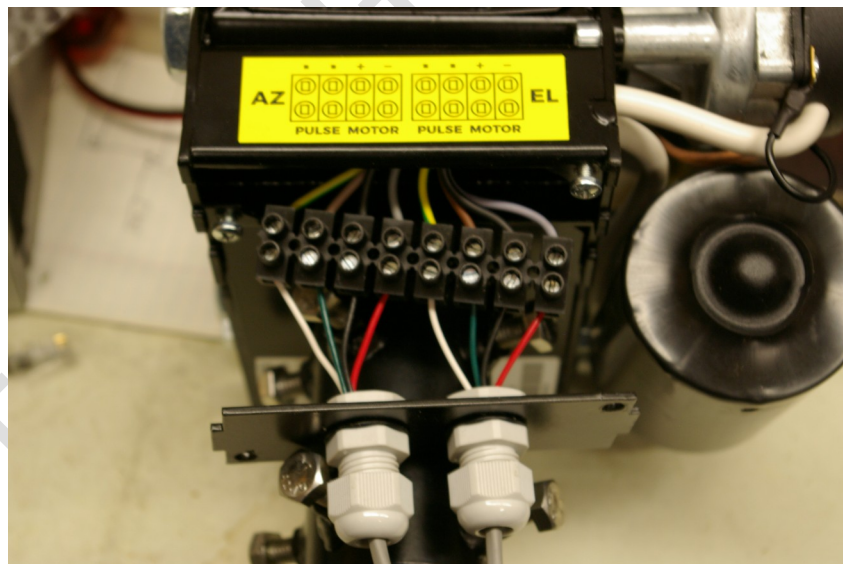

On the Mini-RAS Rotator, remove cover from the Rotator and pull out the 8 pin terminal strip. The Elevation connections are on the Right of the above picture and the Azimuth is on the Left. Pin 1 of the Elevation motor is on the right and pin 4 of the Azimuth Motor is on the left.

Alfa Radio Ltd.

11211 - 154 St. Edmonton, Alberta, Canada T5M 1X8
sales@alfaradio.ca 780-466-5779 www.alfaradio.ca



You can verify this with an ohmmeter and measuring the resistance between pins 1 and 2 and between pins 3 and 4. Expected values are in the table in section 5 of this manual.

Make connections as follows:

Elevation:

- 1 Motor Drive to Elevation 1 on controller connector
- 2 Motor Drive to Elevation 2 on controller connector
- 3 Impulse Sense to Elevation 3 on controller connector
- 4 Impulse Sense to Elevation 4 on controller connector

Azimuth:

- 1 Motor Drive to Azimuth 1 on controller connector
- 2 Motor Drive to Azimuth 2 on controller connector
- 3 Impulse Sense to Azimuth 3 on controller connector
- 4 Impulse Sense to Azimuth 4 on controller connector

When installing any rotator, care must be taken to ensure that the antenna and rotator cables are installed, so that it is not damaged while the antenna is rotated through its normal azimuth operating angular travel. When installing an Alfa Rotator, that normal azimuth operating angular travel can be up to 720 degrees.

Note:

When using Switch Mode power supplies, be aware that inrush current from the rotator motor may trip the power supply overcurrent protection circuits.

In case of trouble, refer to section 3.5 for help.

Alfa Radio Ltd.

11211 - 154 St. Edmonton, Alberta, Canada T5M 1X8
sales@alfaradio.ca 780-466-5779 www.alfaradio.ca



3.2 Using the Alfa Rotator on long cable runs

Since the motor uses relatively low DC voltage, a combination of long cable runs and/or thinner than required cable may reduce the voltage at the motor to an unacceptably low value. It may turn in warm weather or light winds, but the power will not be available to rotate under severe conditions.

While it is easy to recommend installing heavier cable, this may be costly, impractical or both. Don Moman VE6JY, at his contest station, northeast of Edmonton, has a tower that is just over 1700 feet (500 meters) away from the shack. At this distance, the only cost effective alternative was to run 22 gauge underground telephone cable and use relays to switch power from a power supply at the base of the tower. The power supply needs to have enough voltage to supply 13.8 to 18 volts at the motor at 3 to 8 amps. Don uses a battery that is charged by the remaining unused conductors in the telephone cable.

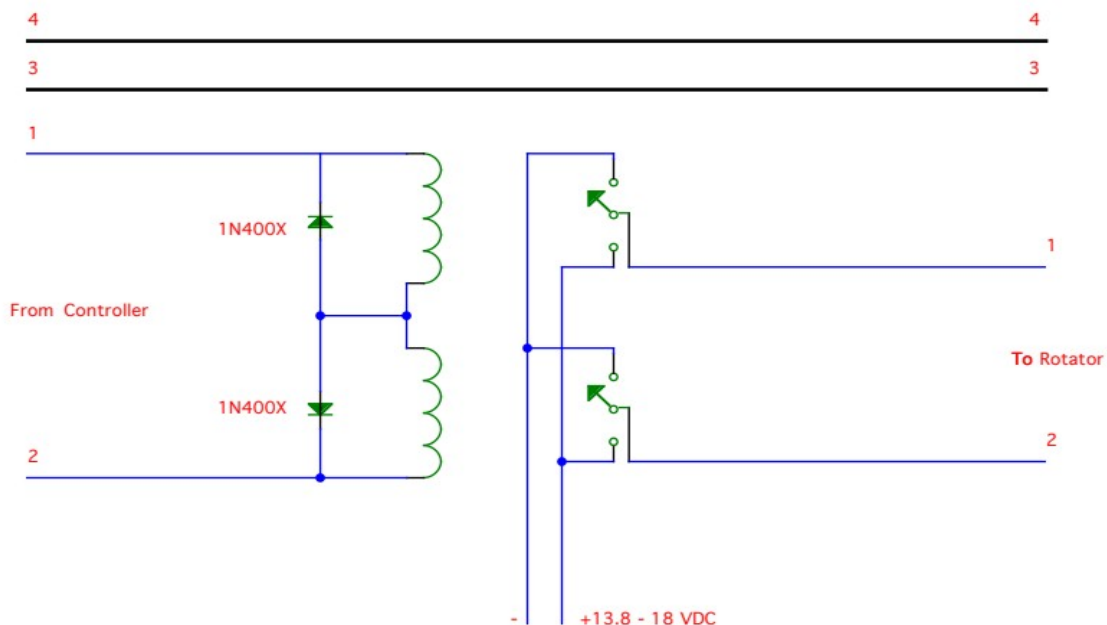

Relays chosen should be suitable for the proper coil voltage, as well as appropriate current carrying capacity of the contacts. A relay

Alfa Radio Ltd.

11211 - 154 St. Edmonton, Alberta, Canada T5M 1X8
sales@alfaradio.ca 780-466-5779 www.alfaradio.ca



capable of 5 to 10 amps DC is adequate. The diodes are general-purpose 1 amp style such as the 1N400X series.

This information is presented as a guide, to help the user realize a solution to the long cable run situation.

3.3 Rotator Mounting Bolts

All mounting bolts on the Alfaspid Rotators are Metric.

Rotator	Bolt Size	Thread Pitch	Length	Wrench or Socket
RAU	M8	1.25	20mm	13mm
Mini-RAS	M8	1.25	25mm	13mm
RAK – RAS	M10	1.5	25mm	17mm
BIG-RAK or BIG-RAS	M10 M12	1.5 1.75	25mm 25mm	17mm 19mm

Alfa Radio Ltd.

11211 - 154 St. Edmonton, Alberta, Canada T5M 1X8
sales@alfaradio.ca 780-466-5779 www.alfaradio.ca



4 Rotator Testing:

It is highly recommended that the rotator controller and rotator be set up on the bench before installing on a tower. This will give the operator a chance to become familiar with the equipment.

The controller is normally expected to be operated from a 13.8 Volt DC supply, however it may be operated from other unregulated DC or AC sources as well. The output of supply source must be from 13.8 to 18 Vdc, 6 Amps minimum.

The polarity of the power to the control box input leads is not critical, as a full wave bridge rectifier on the input will provide the proper polarity to the electronics.

TIP: *Because of several steering diodes in the motor path, the voltage delivered to the motor (neglecting wire loss) **will be about 1.4 volts less than the power supply voltage.** For longer runs and/or thin wiring, a higher voltage (up to approx 18V) to the control unit is beneficial. A simple way to estimate if the voltage to the motor is adequate is by timing the rotation. Under no or a very small load, the 360 degree rotation time with 18V DC or 24V DC are noted in the specifications in section 2. A DC Ammeter in the motor lead is also useful. It should indicate between 1 and 3 amps with a small load. On windy days or a heavy load, the current may fluctuate up to 3 to 5 amps.*



It is highly recommended to ground the Control Box.

Notes - testing and troubleshooting

Azimuth, when looking at the rotator from above:

Pressing should make the rotator move clockwise.

Pressing should make the rotator move counter-clockwise.

If rotation is reversed, switch lines 1 and 2 on the back of the controller on the Azimuth connector.

Alfa Radio Ltd.

11211 - 154 St. Edmonton, Alberta, Canada T5M 1X8
sales@alfaradio.ca 780-466-5779 www.alfaradio.ca



Azimuth impulse sense lines (3 & 4) have no polarity concerns.

Elevation, when looking at the rotator from the elevation drive end:

Pressing should make the rotator move Clockwise.

Pressing should make the rotator move Counter Clockwise.

If rotation is reversed, switch lines 1 and 2 on the back of the controller on the Elevation Connector.

Elevation impulse sense lines (3 & 4) have no polarity concerns.

Part of the protection circuitry involves removing motor power, if the controller receives no sense indication. If the motor turns for a few seconds and then you hear the relay in the control box drop out, the motor has either stalled or there is a problem in the reed switch sense wiring.

Alfa Radio Ltd.

11211 - 154 St. Edmonton, Alberta, Canada T5M 1X8
sales@alfaradio.ca 780-466-5779 www.alfaradio.ca



5 Rotator Troubleshooting

Before contacting Alfa Radio Ltd. Please make the following tests:

NOTE: ON THE ELEVATION ROTATOR THERE ARE MECHANICAL SWITCHES WHICH OPEN THE POWER WHEN THE END LIMIT IS REACHED. A DIODE IS PLACED IN SERIES WITH THE MOTOR. TO TEST FOR THIS, REVERSE THE POWER TO THE MOTOR.

The following are some trouble shooting tips, if for some reason your Alfa will not operate correctly.

It is important to confirm correct operation before installing the rotator on the tower.

Check the Limits - PH and PL settings and rule out overlap.

Simple resistance tests can reveal incorrect or shorted wiring.

Pins 1 and 2 are the motor winding and will have a low resistance. Typically 2-3 ohms.

Pins 3 and 4 are the sense lines and typically will have either an open circuit or have from 600 to 1200 ohms depending on the status of the reed switch in the rotator and the length and gauge of wire used.

There should be no conductivity between 1 and 3 or 1 and 4, or between 2 and 3 or 2 and 4

All lines should have no conductivity to ground.

**** Be careful not to over wind the coax with the next test, as there will be no protection from over turning.**

Find a small 12 volt supply which will deliver 3 to 4 amps. (A small 12 Volt battery will work just fine and is easy to take up the tower)

Alfa Radio Ltd.

11211 - 154 St. Edmonton, Alberta, Canada T5M 1X8
sales@alfaradio.ca 780-466-5779 www.alfaradio.ca



To confirm that the motor runs, you may connect 12 volts D.C. to the lines that go to the motor, pins 1 and 2. It should turn. Reversing the 12 Volts D.C. should cause the motor to turn in the reverse direction.

NOTE: ON THE ELEVATION ROTATOR, THERE ARE MECHANICAL SWITCHES WHICH REMOVE THE POWER TO THE MOTOR WHEN THE END LIMIT IS REACHED. A DIODE IS PLACED IN SERIES WITH THE MOTOR. TO TEST FOR THIS, REVERSE THE POWER TO THE MOTOR. THE UNIT SHOULD TURN.

To confirm that the sense circuit in the rotator is working, connect an ohm meter to the senses lines pins 3 and 4 and apply 12 volts to the motor lines (pins 1 and 2). You should see the ohm meter reading alternate between open circuit and from 600 to 1200 ohms.

Alfa Radio Ltd.

11211 - 154 St. Edmonton, Alberta, Canada T5M 1X8
sales@alfaradio.ca 780-466-5779 www.alfaradio.ca



Pin on Rotator not controller	Typical Reading	Your reading	
Pins 1 to 2	About 2 to 4 Ohms	-----	Depends on the length of wire to rotator
Pins 3 to 4	Open or from 600 to 1200 Ohms	-----	Depends on the status of the read switch
Pins 1 to 3	Open	-----	
Pins 1 to 4	Open	-----	
Pins 2 to 3	Open	-----	
Pins 2 to 4	Open	-----	
Pin 1 to Ground	Open	-----	
Pin 2 to Ground	Open	-----	
Pin 3 to Ground	Open	-----	
Pin 4 to Ground	Open	-----	

Voltage on controller			
Pins 1 to 2	About 12 volts with motor running		Depends on the supply voltage (14 volt applied)
Pins 3 to 4	About 8.5 volts or 2.5 volts		Depends on the status of the read switch and the Supply voltage

Alfa Radio Ltd.

11211 - 154 St. Edmonton, Alberta, Canada T5M 1X8
sales@alfaradio.ca 780-466-5779 www.alfaradio.ca



6 Replacing Reed Switch Sensor:

After completing the troubleshooting test in Section 5 above and determining that a Reed Switch sensor is faulty in one or both motors, replacing the Reed Switches is relatively easy.

It is recommended that this process be done on a bench and not with the Rotator mounted on the tower.

Step 1 : Remove the cover from the faulty motor at the location where the control cable enters the motor.

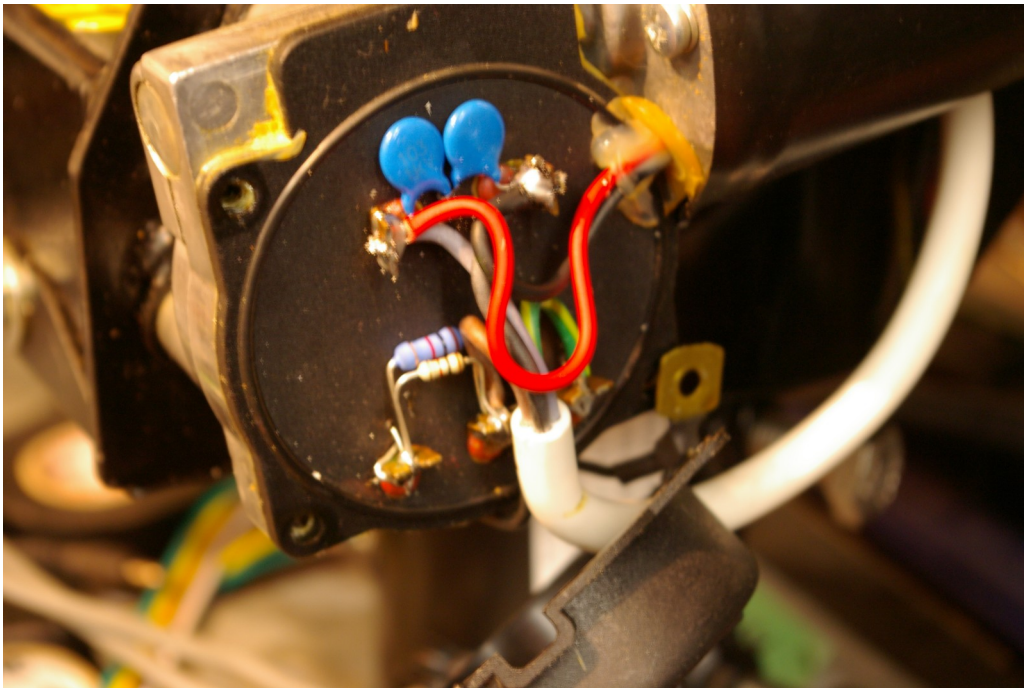

Alfa Radio Ltd.

11211 - 154 St. Edmonton, Alberta, Canada T5M 1X8
sales@alfaradio.ca 780-466-5779 www.alfaradio.ca



Step 2 : Pull down the plastic carrier to expose the Reed Switch which can be seen next to the three copper studs on the left of the picture below.

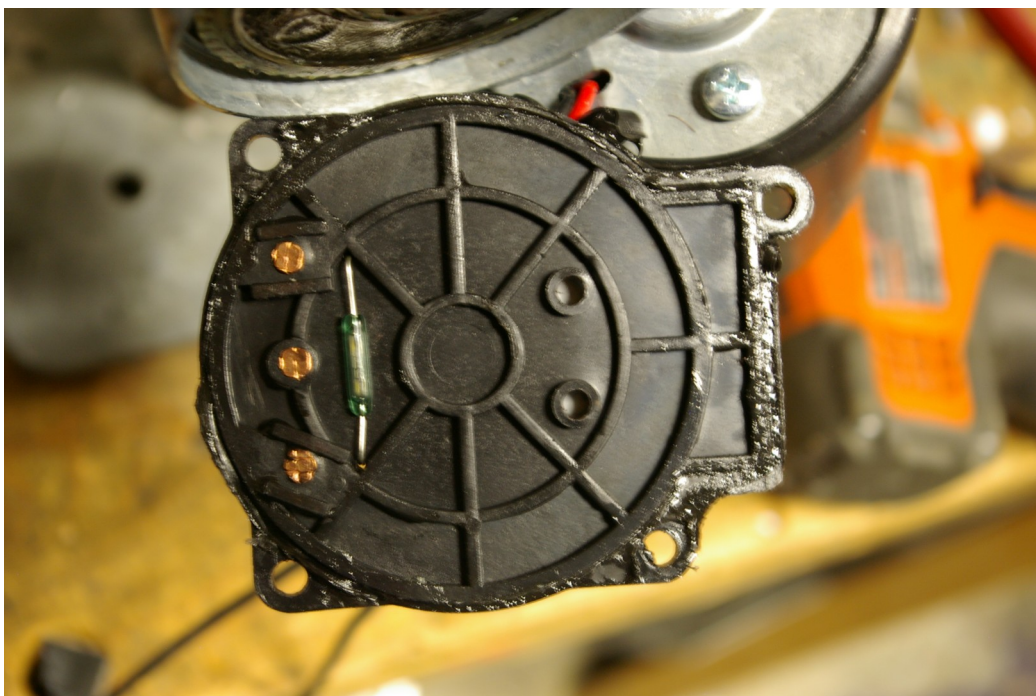

Simply remove the old reed switch and replace it with a new unit.

These Reed Switches are quite common and can be obtained from most Electronic supply stores throughout the world. As a last resort, contact Alfa Radio for replacement reed switches.

Cautions:

1. Make sure that the flat side of the reed switch is facing you when you look at the switch, as in the picture above.
2. Reed switches are rather fragile. When installing the switch, take extreme care to avoid putting any strain on the glass part of the switch.
3. After installation is complete, be sure to bench test the rotator before re-installing in the tower.

Alfa Radio Ltd.

11211 - 154 St. Edmonton, Alberta, Canada T5M 1X8
sales@alfaradio.ca 780-466-5779 www.alfaradio.ca



12 MONTH LIMITED WARRANTY

Alfa Rotators and controllers

Alfa Radio Ltd. warrants to original purchaser of the product, that the product will be free from defects in material and workmanship for the following periods after such date of purchase: Material - 12 months Workmanship - 12 months.

Alfa Radio Ltd. will, at its discretion, repair or replace free of charge such defective products subject to the following conditions:

1. Delivery of the product **prepaid** to **Alfa Radio Ltd.** or its authorized dealer.
2. Determination by **Alfa Radio Ltd.** that a defect exists and is covered by the limited warranty.
3. Defects due to alteration, repair by an unauthorized person, misuse, accidental damage, lightning strikes, use of the equipment for purposes other than those for which it was designed, and the like, are NOT COVERED by this limited warranty. Repairs in these cases will be subject to normal service charges.
4. Damage to an Alfa rotator or controller caused by using said rotator or controller with a rotator or controller manufactured by any other manufacturer will NOT BE COVERED by this limited warranty.
5. Repairs and replacement parts are covered under this limited warranty only for the remaining term of the original limited warranty.
6. Under no circumstances is **Alfa Radio Ltd.** liable for consequential damages to person(s) or property by the use of this product.
7. **Alfa Radio Ltd.** reserves the right to make changes or improvements in design or manufacture without incurring any obligations to install such changes in any of the products previously manufactured.
8. All claims of defect or shortage should be sent prepaid to:

Alfa Radio Ltd.

11211 - 154 Street, Edmonton, Alberta, T5M 1X8, CANADA

and must be accompanied by a letter describing the problem in detail along with a copy of your proof-of-purchase.

Contact **Alfa Radio Ltd.** before sending.